

Pilot to Open	Model No.	Cavity	Description	Flow*	Pressure	Page
	RPC 04	NCS04/3	Pilot Operated Check Valve, Pilot to Open	12 l/min [3 US gal/min]	210 bar [3000 psi]	08.6
	RPC 06	NCS06/3		25 l/min [7 US gal/min]	315 bar [4500 psi]	08.7
	CP450-1	SDC10-3		30 l/min [8 US gal/min]	240 bar [3480 psi]	08.8
	RPC 12	NCS12/3		70 l/min [18 US gal/min]	315 bar [4500 psi]	08.9

Pilot to Open	Model No.	Cavity	Description	Flow*	Pressure	Page
	CP458-2	SDC08-3	Pilot Operated Check Valve, Reverse Pilot to Open	20 l/min [5 US gal/min]	210 bar [3000 psi]	08.10
	MC10-RO	SDC10-3S		45 l/min [12 US gal/min]	250 bar [3600 psi]	08.11
	CP451-2	CP12-3S		95 l/min [25 US gal/min]	210 bar [3000 psi]	08.12
	CP452-2	SDC16-3S		130 l/min [34 US gal/min]	210 bar [3000 psi]	08.13
	CP453-2	CP20-3S		230 l/min [61 US gal/min]	210 bar [3000 psi]	08.14

Pilot to Open	Model No.	Cavity	Description	Flow*	Pressure	Page
	RPV 06	NCS06/4	Pilot Operated Check Valve, Pilot-to-open with drain	30 l/min [8 US gal/min]	315 bar [4500 psi]	08.15

* Flow ratings are based on a pressure drop of 7 bar [100 psi] unless otherwise noted. They are for comparison purposes only.

Symbol	Model No.	Cavity	Description	Flow*	Pressure	Page
	CP453-5	SDC20-2	Pilot Operated Check Valve, Reverse Pilot-to-open with vent	250 l/min [66 US gal/min]	350 bar [5000 psi]	08.16

Pilot to Close	Model No.	Cavity	Description	Flow*	Pressure	Page
	CP460-1	SDC10-3	Pilot Operated Check Valve, Pilot to Close	45 l/min [12 US gal/min]	210 bar [3000 psi]	08.17
	CP461-1	CP12-3S		115 l/min [30 US gal/min]	210 bar [3000 psi]	08.18
	CP462-1	SDC16-3S		190 l/min [50 US gal/min]	210 bar [3000 psi]	08.19

Dual Pilot-Operated Checks	Model No.	Cavity	Description	Flow*	Pressure	Page
	CP410-1	none	Pilot Operated Check Valve, Catalog HIC	85 l/min [22 US gal/min]	210 bar [3000 psi]	08.20

* Flow ratings are based on a pressure drop of 7 bar [100 psi] unless otherwise noted. They are for comparison purposes only.

MOTION CONTROL VALVES

Motion control valves, also referred to as load holding valves, are used to control the motion of a load in the following ways:

- Prevent a load from dropping in case of hose or tube failure.
- Prevent a load from drifting caused by directional control valve spool leakage.
- Provide smooth, modulated motion when the load is in a lowering or run-away mode.
- Provide smooth, modulated motion when the directional control valve is suddenly closed.

There are two basic types of motion control valves:

- Pilot-operated, or pilot-to-open check valves will satisfy the first two of the above requirements.
- Counterbalance valves will satisfy all four of the above requirements.

Pilot operated check valves



PILOT-OPERATED CHECK VALVES

Pilot-operated, or pilot-to-open check valves will positively hold a pressurized load and will release the load upon application of a pressure signal to the pilot port. Pilot-operated check valves are available as individual cartridges, standard **Cartridge-In-Body (CIB)** packages, or can be created in custom manifolds by using a standard check valve such as CV10-NP with a guided pilot piston. For more information on pilot pistons, see Accessories.

Individual cartridges

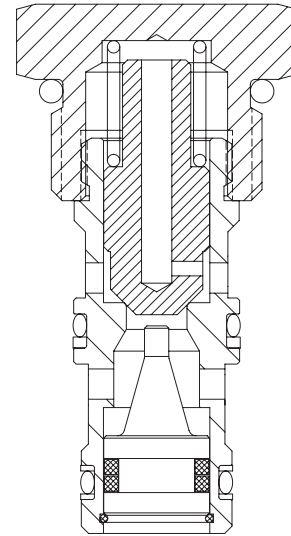

P103 070

Cartridge in body

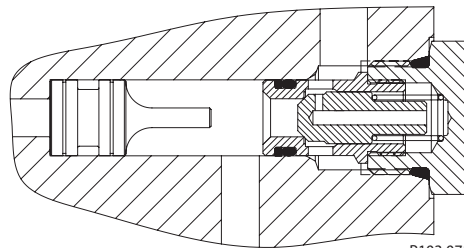

P103 071

A typical circuit application for pilot-operated check valves contains a pump, directional control valve, and an actuator. Without a pilot-operated check valve the load will drift down due to spool leakage if the directional control valve is centered with the load raised. Additionally there is no protection against the load dropping in the event of hydraulic line failure. Adding a pilot-operated check valve helps prevent cylinder drift and provides protection against hose or tube failure. In this circuit, moving the directional control valve to the right causes the cylinder to extend. When the directional control valve is centered, the pilot-operated check valve will prevent leakage and lock the cylinder in position. Moving the directional control valve to the left sends pressure/flow to the rod end of the cylinder. This pressure also acts on the pilot piston to open the check valve and allow the load to be lowered.

Typical circuit application

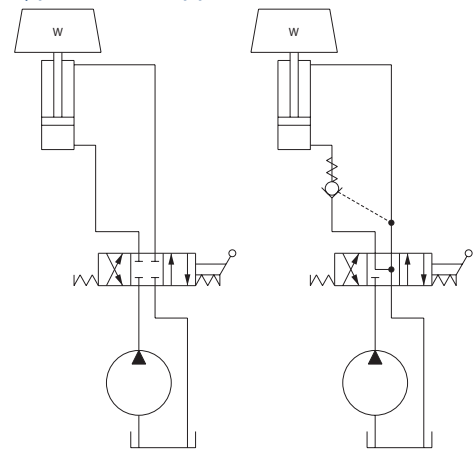

P103 072

PILOT-OPERATED CHECK VALVES (continued)

The pressure required to pilot open the check valve can be calculated by:

$$P = \frac{W + (P_c \cdot A_b)}{(A_b \cdot R) - A_r} \quad \text{cylinder retracts}$$

$$P = \frac{W + (P_c \cdot A_r)}{(A_r \cdot R) - A_b} \quad \text{cylinder extends}$$

W = Load

P_c = Check valve crack pressure (typically 0.34-4.5 bar [5-65 psi]; consult catalog sheets for details)

A_b = Cylinder bore area

A_r = Cylinder rod area

R = Check valve pilot ratio (typically 3:1 or 4:1; consult catalog sheets for details)

Note that these equations are idealized and do not consider any backpressure in the circuit, which is additive to the pressure required to pilot open the check valve.

Some additional guidelines for pilot-operated check valve applications:

- Use pilot-operated check valves for load holding, not for motion (speed) control. Pilot-operated check valves are on-off, non-modulating devices. Trying to use a pilot-operated check valve to control an overrunning load can result in severely unstable motion. For motion (speed) control of overrunning loads, use a counterbalance valve.
- Use caution when applying pilot-operated check valves to the rod end of a cylinder. Cylinders with large rod:bore diameter ratios may intensify rod pressure to a point where the required pilot pressure may be dangerously high— refer to the above equations. If intensification creates application concerns, consider using a counterbalance valve.
- Do not use pilot-operated check valves with closed-center, directional control valves. Pressure trapped between the directional control valve and the pilot-operated check valve can pilot the check valve open and result in undesired load motion.
- Locate pilot-operated check valves at or near the actuator to provide maximum load holding protection in the event of hydraulic line failure.

Closed center, directional control valves

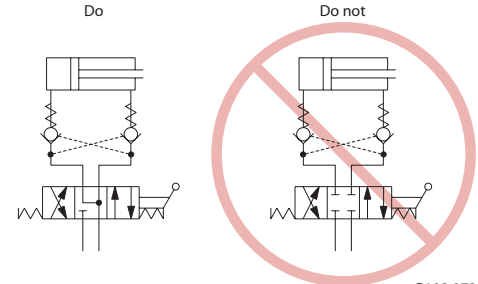

P103 073

Cartridge Valves Technical Information

Pilot operated check valves

Pilot to Open

RPC 04

OPERATION

This is a pilot-to-open check valve.

Schematic

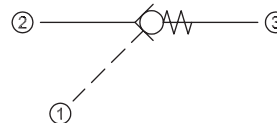

P102 381E

SPECIFICATIONS

Theoretical performance

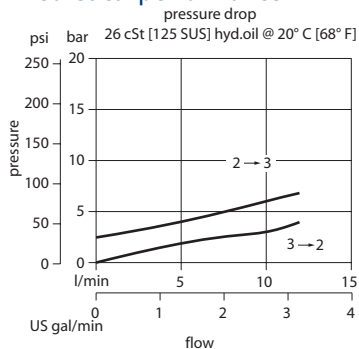

P103 679E

Specifications

Rated pressure	210 bar [3000 psi]
Rated flow at 7 bar [100 psi]	12 l/min [3 US gal/min]
Weight	0.06 kg [0.13 lb]
Pilot ratio	3.2:1
Cavity	NCS04/3

Note: A piston seal requires a 4.5 bar [65 psi] or greater return spring.

DIMENSIONS

mm [in]

Cross-sectional view

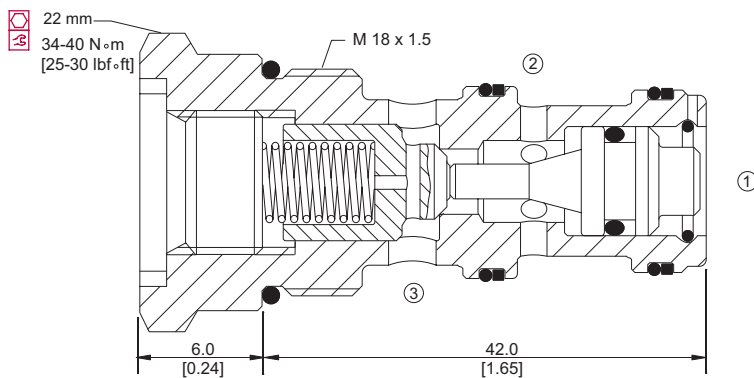

P103 652

ORDERING INFORMATION

RPC 04 - 2.5 - OR - 00 - V

<p>Pressure to open 0.5 = 0.5 bar [7 psi] 2.5 = 2.5 bar [36 psi] 5.0 = 5 bar [72 psi]</p>	<p>Seals V = Viton Omit = Buna-N</p>	<p>Seal kit 230000450 230000160</p>
<p>Piston seals OR = Seal Omit = No seal</p>	<p>Housing and ports 00 = No Housing SE1/4 = AL, 1/4 BSP SE4S = AL, #4 SAE SE6S = AL, #6 SAE Other housings available</p>	<p>Housing P/N No Housing NCS04/3-SE-1/4 NCS04/3-SE-4S NCS04/3-SE-6S</p>

P103 706E

Cartridge Valves Technical Information

Pilot operated check valves

Pilot to Open

RPC 06

OPERATION

This is a pilot-to-open check valve.

Schematic

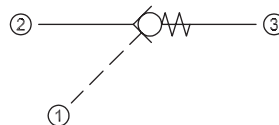

P102 381E

SPECIFICATIONS

Theoretical performance

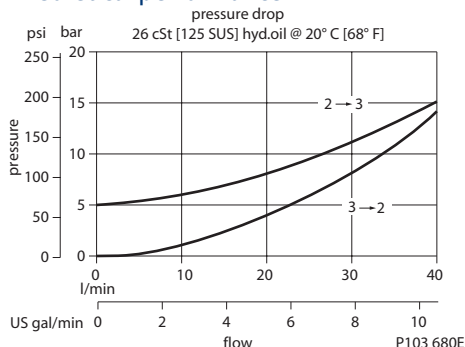

Specifications

Rated pressure	315 bar [4500 psi]
Rated flow at 7 bar [100 psi]	25 l/min [7 US gal/min]
Weight	0.10 kg [0.22 lb]
Pilot ratio	3.4:1
Cavity	NCS06/3

Note: A piston seal requires a 4.5 bar [65 psi] or greater return spring.

DIMENSIONS

mm [in]

Cross-sectional view

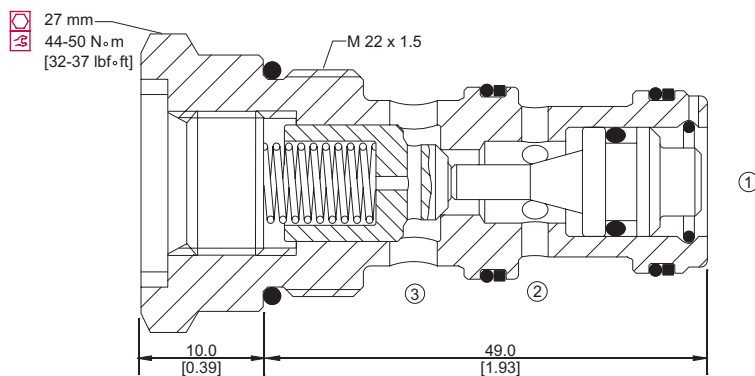

P103 653

ORDERING INFORMATION

RPC 06 - 5 - OR - 00 - V

Pressure to open 0.5 = 0.5 bar [7 psi] 5 = 5 bar [73 psi]	Seals V = Viton Omit = Buna-N	Seal kit 230000110 230000070
Piston seals OR = Seals Omit = No seals	Housing and ports 00 = No Housing SE3/8 = AL, 3/8 BSP SE3/4 = AL, 3/4 BSP SE6S = AL, #6 SAE SE8S = AL, #8 SAE Other housings available	Housing P/N No Housing NCS06/3-SE-3/8 NCS06/3-SE-1/2 NCS06/3-SE-6S NCS06/3-SE-8S

P103 707E

Pilot operated check valves
RPC 06

Cartridge Valves Technical Information

Pilot operated check valves

Pilot to Open

CP450-1

OPERATION

This valve is a pilot-to-open check valve.

Schematic

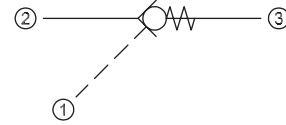

P102 381E

SPECIFICATIONS

Theoretical performance

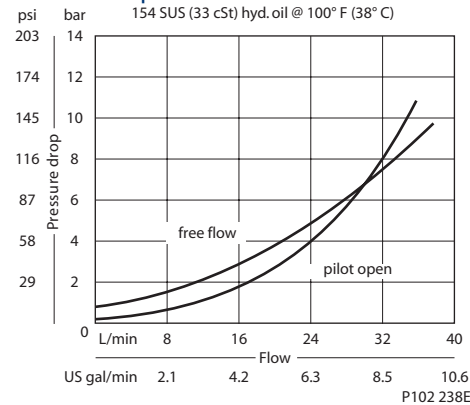

Specifications

Rated pressure	240 bar [3480 psi]
Rated flow at 7 bar [100 psi]	30 l/min [8 US gal/min]
Leakage	6 drops/min @ Rated pressure
Weight	0.09 kg [0.20 lb]
Pilot ratio	3.0:1
Cavity	SDC10-3

Note: A piston seal requires a 4.5 bar [65 psi] or greater return spring.

DIMENSIONS

mm [in]

Cross-sectional view

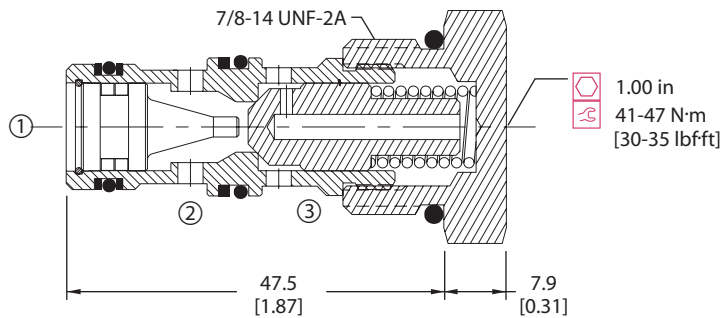

P102 236E

ORDERING INFORMATION

CP450 - 1 - B - 8S - 015 - 0

Seals	Seal kit 120570 120571	Piston seals 0 = No seals S = Seals included
B = Buna-N V = Viton		Cracking Pressure
Body and ports	Body P/N No body CP10-3-6S CP10-3-8S SDC10-3-SE-3B SDC10-3-SE-4B	bar [psi] 065 = 4.48 [65] 115 = 7.90 [115] 200 = 13.8 [200] 315 = 21.8 [315]

P102 067E

Pilot operated check valves
CP450-1

Cartridge Valves Technical Information

Pilot operated check valves

Pilot to Open

RPC 12

OPERATION

This is a pilot-to-open check valve.

Schematic

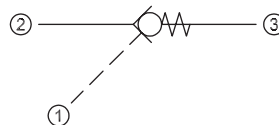

P102 381E

SPECIFICATIONS

Theoretical performance

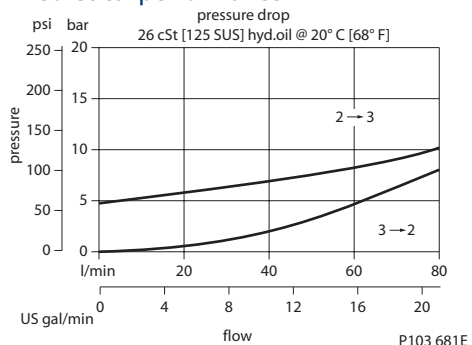

Specifications

Rated pressure	315 bar [4500 psi]
Rated flow at 7 bar [100 psi]	70 l/min [18 US gal/min]
Weight	0.20 kg [0.44 lb]
Pilot ratio	2.8:1
Cavity	NCS12/3

Note: A piston seal requires a 4.5 bar [65 psi] or greater return spring.

DIMENSIONS

mm [in]

Cross-sectional view

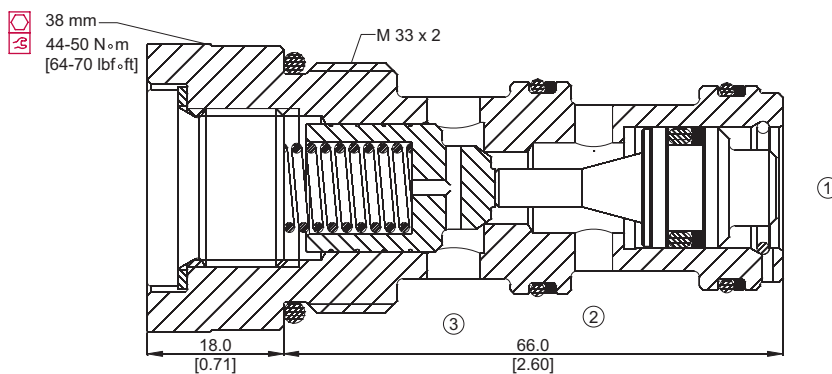

P103 654

ORDERING INFORMATION

RPC 12 - 5 - OR - 00 - V

Pressure to open 0.5 = 0.5 bar [7 psi] 5 = 5 bar [73 psi]	Seals V = Viton Omit = Buna-N	Seal kit 230000360 230000130
Piston seals OR = Seals Omit = No seals	Housing and ports 00 = No Housing SE1/2 = AL, 1/2 BSP SE3/4 = AL, 3/4 BSP SE8S = AL, #8 SAE SE12S = AL, #12 SAE Other housings available	Housing P/N No Housing NCS12/3-SE-1/2 NCS12/3-SE-3/4 NCS12/3-SE-8S NCS12/3-SE-12S

P103 708E

Pilot operated check valves
RPC 12

Cartridge Valves Technical Information

Pilot operated check valves

Pilot to Open

CP458-2

OPERATION

This valve is a pilot-to-open check valve.

Schematic

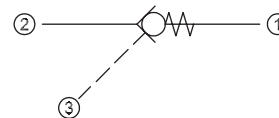

P102 377E

SPECIFICATIONS

Theoretical performance

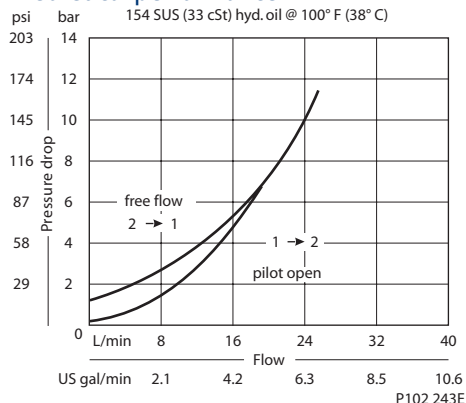

Specifications

Rated pressure	210 bar [3000 psi]
Rated flow at 7 bar [100 psi]	20 l/min [5 US gal/min]
Leakage	6 drops/min @ Rated pressure
Weight	0.07 kg [0.15 lb]
Pilot ratio	2.8:1
Cavity	SDC08-3

Note: A piston seal requires a 4.5 bar [65 psi] or greater return spring.

DIMENSIONS

mm [in]

Cross-sectional view

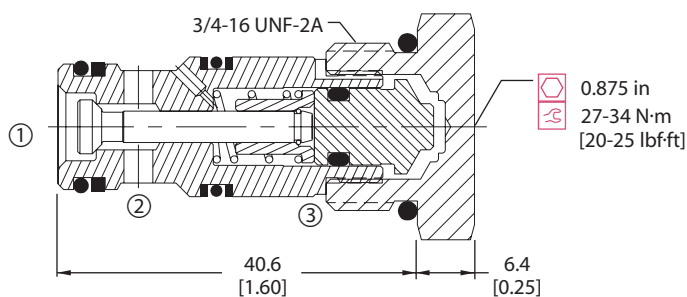

P102 242E

ORDERING INFORMATION

CP458 - 2 - B - 6S - 065 - 0

Seals B = Buna-N V = Viton	Seal kit 120250 120253	Piston seals 0 = No seals S = Seals included
Housing and ports 0 = No Housing SE2B = Al, 1/4 BSP SE3B = Al, 3/8 BSP 4S = Al, #4 SAE 6S = Al, #6 SAE Other housings available	Housing P/N No Housing SDC08-3-SE-2B SDC08-3-SE-3B CP08-3-4S CP08-3-6S	Crack Pressure bar [psi] 065 = 4.48 [65]

P102 076E

Cartridge Valves Technical Information

Pilot operated check valves

Pilot to Open

MC10-RO

OPERATION

This is a pilot-to-open check valve.

Schematic

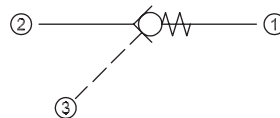

P102 377E

SPECIFICATIONS

Theoretical performance

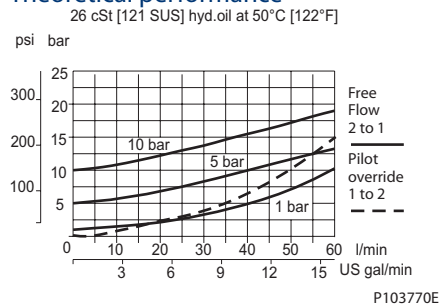

Specifications

Rated pressure	250 bar [3600 psi]
Rated flow at 7 bar [100 psi]	45 l/min [12 US gal/min]
Leakage	6 drops/min @
Weight	0.12 kg [0.26 lb]
Pilot ratio	3.0:1
Cavity	SDC10-3S

Note: A piston seal requires a 4.5 bar [65 psi] or greater return spring.

DIMENSIONS

mm [in]

Cross-sectional view

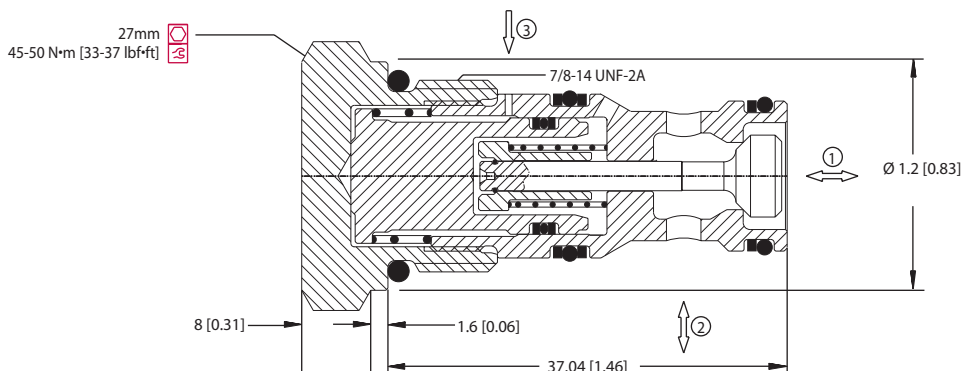

P103 753

ORDERING INFORMATION

MC10-RO-5-OR-A-B-6S

Crack Pressure		
1 = 1 bar [15 psi]		
5 = 5 bar [73 psi]		
10 = 10 bar [145 psi]		
Piston seals		
Omit = No seal		
OR = Seals included		
Housing and ports		Housing P/N
00 = No Housing		No Housing
SE3B = Al, 3/8 BSP		SDC10-3S-SE-3B
SE4B = Al, 1/2 BSP		SDC10-3S-SE-4B
6S = Al, #6 SAE		SDC10-3S-6S/6S
8S = Al, #8 SAE		SDC10-3S-8S/6S
Other housings available		
Seals	Seal kit	
B = Buna-N	35401419	
V = Viton	35401519	

P103 771E

Pilot operated check valves
MC10-RO

Cartridge Valves Technical Information

Pilot operated check valves

Pilot to Open

CP451-2

OPERATION

This valve is a pilot-to-open check valve.

Schematic

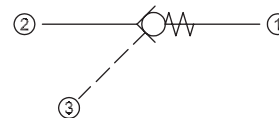

P102 377E

SPECIFICATIONS

Theoretical performance

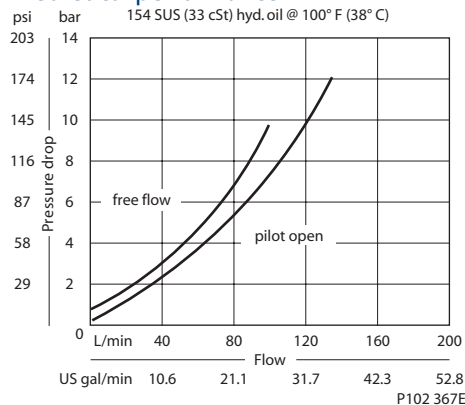

Specifications

Rated pressure	210 bar [3000 psi]
Rated flow at 7 bar [100 psi]	95 l/min [25 US gal/min]
Leakage	6 drops/min @ Rated pressure
Weight	0.21 kg [0.46 lb]
Pilot ratio	3:1
Cavity	CP12-3S

Note: A piston seal requires a 4.5 bar [65 psi] or greater return spring.

DIMENSIONS

mm [in]

Cross-sectional view

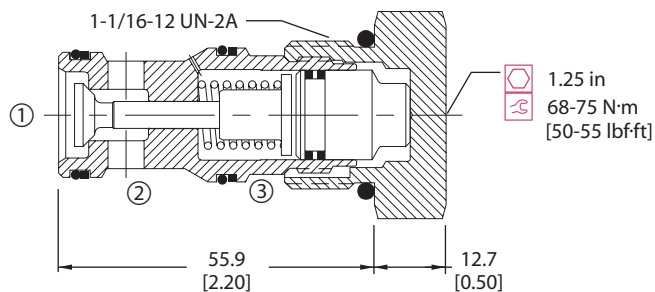

P102 354E

ORDERING INFORMATION

CP451 - 2 - B - 12S - 065 - 0

Seals		Piston seals	
B = Buna-N	Seal kit 120204	0 = No seals	
V = Viton	Seal kit 120205	S = Seals included	
Housing and ports	Housing P/N	Crack Pressure	
0 = No Housing	No Housing	bar [psi]	
4B = Al, 1/2 BSP	CP12-3S-4B/2B	065 = 4.48 [65]	
6B = Al, 3/4 BSP	CP12-3S-6B/2B		
10S = Al, #10 SAE	CP12-3S-10S/4S		
12S = Al, #12 SAE	CP12-3S-12S/4S		
Other housings available			

P102 063E

OPERATION

This valve is a pilot-to-open check valve.

Schematic

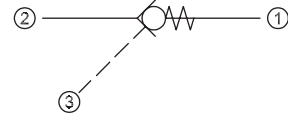

P102 377E

SPECIFICATIONS

Theoretical performance

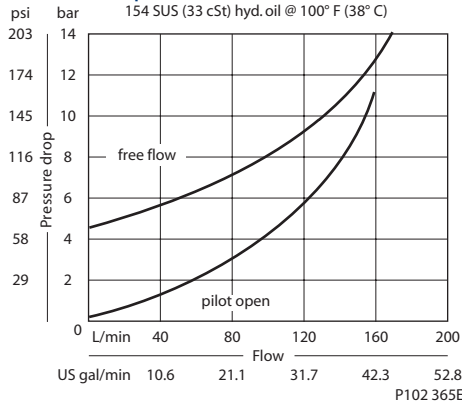

Specifications

Rated pressure	210 bar [3000 psi]
Rated flow at 7 bar [100 psi]	130 l/min [34 US gal/min]
Leakage	6 drops/min @ Rated pressure
Weight	0.29 kg [0.64 lb]
Pilot ratio	3:1
Cavity	SDC16-3S

Note: A piston seal requires a 4.5 bar [65 psi] or greater return spring.

DIMENSIONS

mm [in]

Cross-sectional view

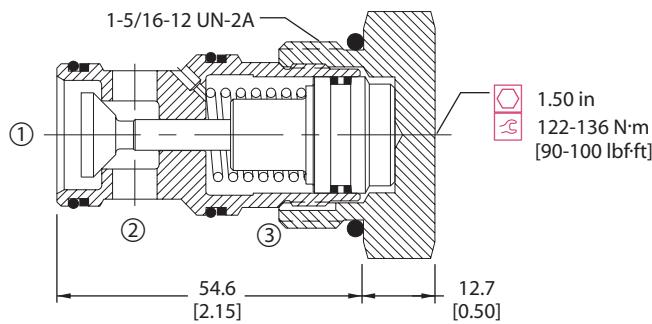

P102 352E

ORDERING INFORMATION

CP452 - 2 - B - 16S - 065 - 0

Seals B = Buna-N V = Viton	Seal kit 120033 120034	Piston seals 0 = No seals S = Seals included
Housing and ports 0 = No Housing 6B = Al, 3/4 BSP 8B = Al, 1 BSP 12S = Al, #12 SAE 16S = Al, #16 SAE Other housings available	Housing P/N No Housing CP16-3S-6B/2B CP16-3S-8B/2B CP16-3S-12S/4S CP16-3S-12S/4S	Crack Pressure bar [psi] 065 = 4.48 [65]

P102 081E

Pilot operated check valves
CP452-2

Cartridge Valves Technical Information

Pilot operated check valves

Pilot to Open

CP453-2

OPERATION

This valve is a pilot-to-open check valve.

Schematic

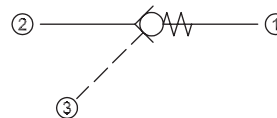

P102 377E

SPECIFICATIONS

Theoretical performance

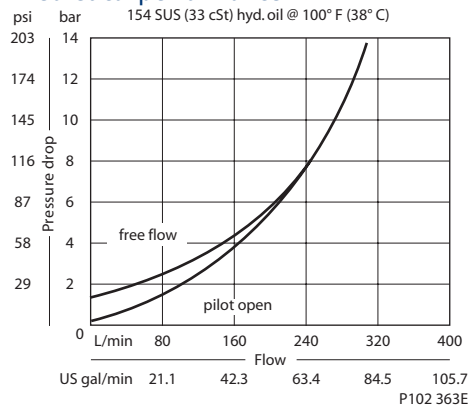

Specifications

Rated pressure	210 bar [3000 psi]
Rated flow at 7 bar [100 psi]	230 l/min [61 US gal/min]
Leakage	6 drops/min @ Rated pressure
Weight	0.66 kg [1.46 lb]
Pilot ratio	3:1
Cavity	CP20-3S

Note: A piston seal requires a 4.5 bar [65 psi] or greater return spring.

DIMENSIONS

mm [in]

Cross-sectional view

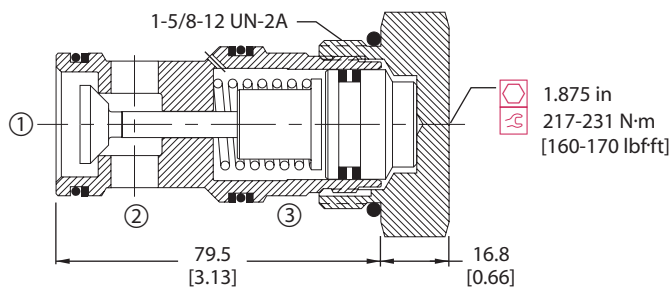

P102 350E

ORDERING INFORMATION

CP453 - 2 - B - 20S - 065 - 0

Seals B = Buna-N V = Viton	Seal kit 120380 120381	Piston seals 0 = No seals S = Seals included
Housing and ports 0 = No Housing 8B = Al, 1 BSP 10B = Al, 1-1/4 BSP 16S = Al, #16 SAE 20S = Al, #20 SAE Other housings available	Housing P/N No Housing CP20-3S-8B/2B CP20-3S-10B/2B CP20-3S-16S/4S CP20-3S-20S/4S	Crack Pressure 065 = 4.48 bar [psi] [65]

P102 086E

Cartridge Valves Technical Information

Pilot operated check valves

Pilot to Open with Drain

RPV 06

OPERATION

This is a pilot-to-open check valve with an internal drain.

Schematic

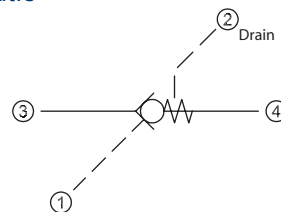

P103 511

SPECIFICATIONS

Theoretical performance

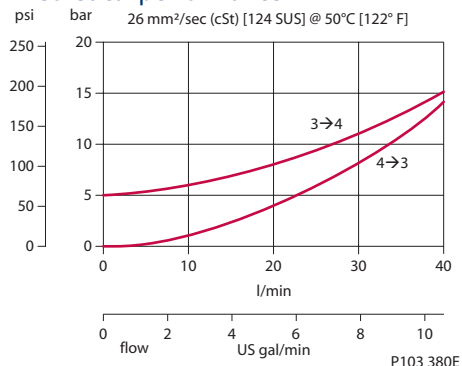

Specifications

Rated pressure	315 bar [4500 psi]
Rated flow at bar [psi]	30 l/min [8 US gal/min]
Weight	0.13 kg [0.29 lb]
Pilot ratio	3.4:1
Cavity	NCS06/4

Note: A piston seal requires a 4.5 bar [65 psi] or greater return spring.

DIMENSIONS

mm [in]

Cross-sectional view

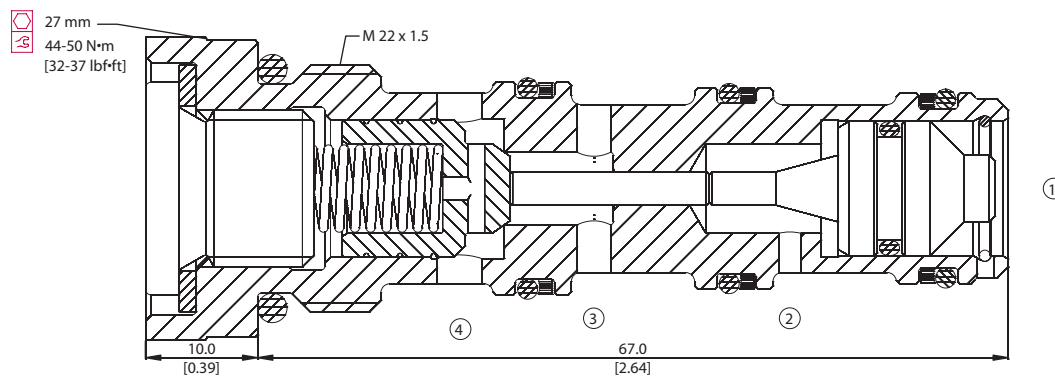

P103 379

ORDERING INFORMATION

RPV 06 - 5 - OR - 00 - V

Piston seals
OR = Seals
Omit = No seals

Seals
V = Viton
Omit = Buna-N

Seal Kit
Consult factory
230000080

Housing and ports
00 = No Housing
L3/8 = AL, 3/8 BSP
L3/4 = AL, 3/4 BSP
L6S = AL, #6 SAE
L8S = AL, #8 SAE
Other housings available

Housing P/N
No Housing
NCS06/4-L-3/8
NCS06/4-L-1/2
NCS06/4-L-6S
NCS06/4-L-8S

P103 381E

Pilot operated check valves
RPV 06

Cartridge Valves Technical Information

Pilot operated check valves

Pilot to Open with Drain

CP453-5

OPERATION

This is a pilot-to-open check valve with an external pilot connection.

Schematic

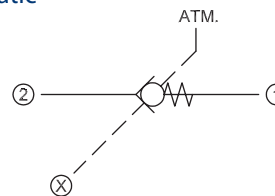

P103 509

SPECIFICATIONS

Theoretical performance

33 cSt [154 SUS] hyd.oil @ 38°C [100° F]

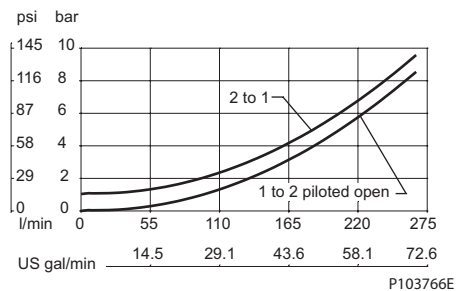

P103766E

Specifications

Rated pressure	350 bar [5000 psi]
Rated flow at 7 bar [100 psi]	250 l/min [66 US gal/min]
Leakage	6 drops/min @ Rated pressure
Weight	1.23 kg [2.71 lb]
Pilot ratio	4:1
Cavity	SDC20-2

Note: A piston seal requires a 4.5 bar [65 psi] or greater return spring.

DIMENSIONS

mm [in]

Cross-sectional view

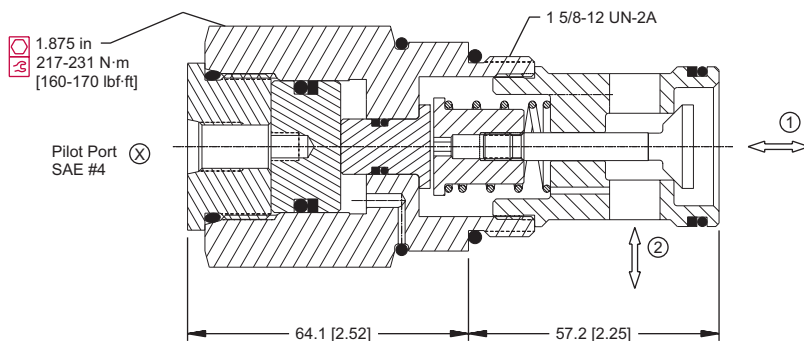

P103 751

ORDERING INFORMATION

Seals		Seal kit		CP453-5-B-16S-4-065		Crack Pressure	
B = Buna-N	120011					065 = 4.3	65
V = Viton	120012					100 = 6.9	100
Housing and ports		Housing P/N					
0 = No Housing		No Housing					
8B = AL, 1 BSP		CP20-2-8B					
10B = AL, 1-1/4 BSP		CP20-2-10B					
16S = AL, #16 SAE		CP20-2-16S					
20S = AL, #20 SAE		CP20-3-20S					
Other housings available							
						Pilot ratio	
						4 = 4:1	

P103 767E

Pilot operated check valves
CP453-5

Cartridge Valves Technical Information

Pilot operated check valves

Pilot to Close

CP460-1

OPERATION

This valve is a pilot-to-close check valve.

Schematic

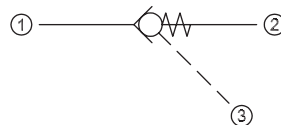

P102 378E

SPECIFICATIONS

Theoretical performance

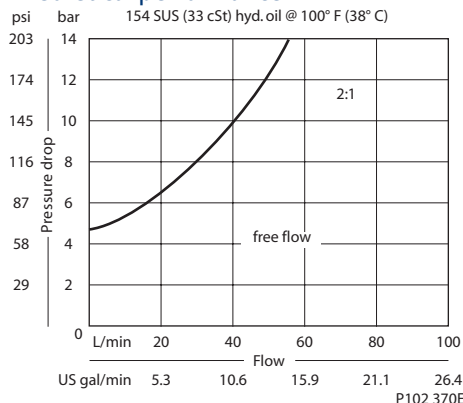

Specifications

Rated pressure	210 bar [3000 psi]
Rated flow at 7 bar [100 psi]	22 l/min [5.8 US gal/min]
Leakage	6 drops/min @ Rated pressure
Weight	0.10 kg [0.21 lb]
Pilot ratio	2:1
Cavity	SDC10-3

Note: A piston seal requires a 4.5 bar [65 psi] or greater return spring.

DIMENSIONS

mm [in]

Cross-sectional view

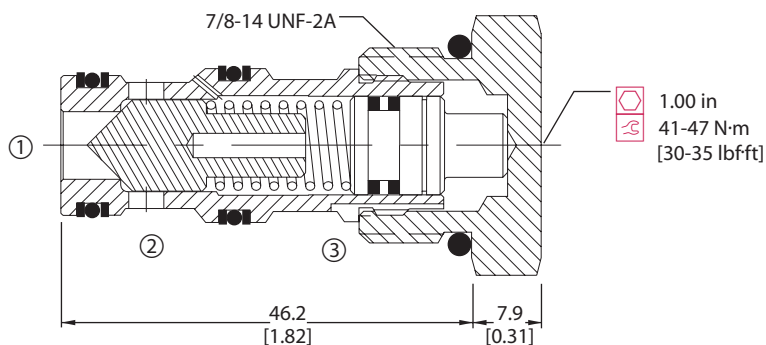

P102 356E

ORDERING INFORMATION

CP460 - 1 - B - 8S - 2 - 065 - 0

seals	Seal kit	Piston seals	0 = No seals	Crack Pressure	065 = 4.48	[psi]
B = Buna-N	120009	S = Seals included		bar	[65]	
V = Viton	120010					
Housing and ports	Housing P/N			Pilot ratio	2 = 2:1	
0 = No Housing	No Housing					
E3B = Al, 3/8 BSP	SDC10-3-SE-3B					
E4B = Al, 1/2 BSP	SDC10-3-SE-4B					
6S = Al, #6 SAE	CP10-3-6S					
8S = Al, #8 SAE	CP10-3-8S					
Other housings available						

P102 072E

Cartridge Valves Technical Information
 Pilot operated check valves
 Pilot to Close
 CP461-1

OPERATION

This valve is a pilot-to-close check valve.

Schematic

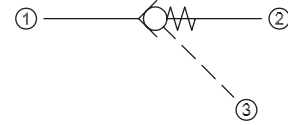

P102 378E

SPECIFICATIONS

Theoretical performance

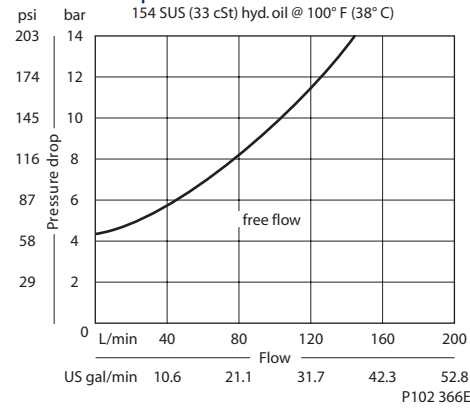

Specifications

Rated pressure	210 bar [3000 psi]
Rated flow at 7 bar [100 psi]	60 l/min [16 US gal/min]
Leakage	6 drops/min @ Rated pressure
Weight	0.21 kg [0.47 lb]
Pilot ratio	2.3:1
Cavity	CP12-3S

Note: A piston seal requires a 4.5 bar [65 psi] or greater return spring.

DIMENSIONS

mm [in]

Cross-sectional view

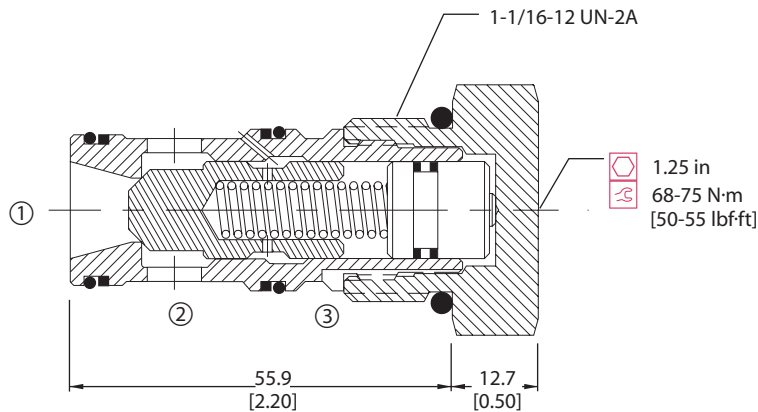

P102 353E

ORDERING INFORMATION

CP461 - 1 - B - 12S - 065 - 0

Seals

B = Buna-N
 V = Viton

Seal kit
 120335
 120336

Housing and ports

0 = No Housing
 4B = Al, 1/2 BSP
 6B = Al, 3/4 BSP
 10S = Al, #10 SAE
 12S = Al, #12 SAE
 Other housings available

Housing P/N

No Housing
 CP12-3S-4B/2B
 CP12-3S-6B/2B
 CP12-3S-10S/4S
 CP12-3S-12S/4S

Piston seals

0 = No seals
 S = Seals included

Crack Pressure

065 = 4.48 bar [65 psi]

P102 077E

Pilot operated check valves
 CP461-1

Cartridge Valves Technical Information

Pilot operated check valves

Pilot to Close

CP462-1

OPERATION

This valve is a pilot-to-close check valve.

Schematic

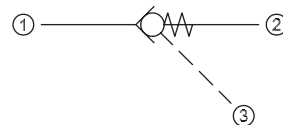

P102 378E

SPECIFICATIONS

Theoretical performance

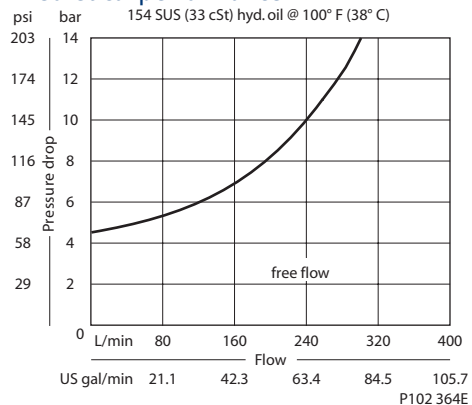

Specifications

Rated pressure	210 bar [3000 psi]
Rated flow at 7 bar [100 psi]	190 l/min [50 US gal/min]
Leakage	6 drops/min @ Rated pressure
Weight	0.29 kg [0.64 lb]
Pilot ratio	2.3:1
Cavity	SDC16-3S

Note: A piston seal requires a 4.5 bar [65 psi] or greater return spring.

DIMENSIONS

mm [in]

Cross-sectional view

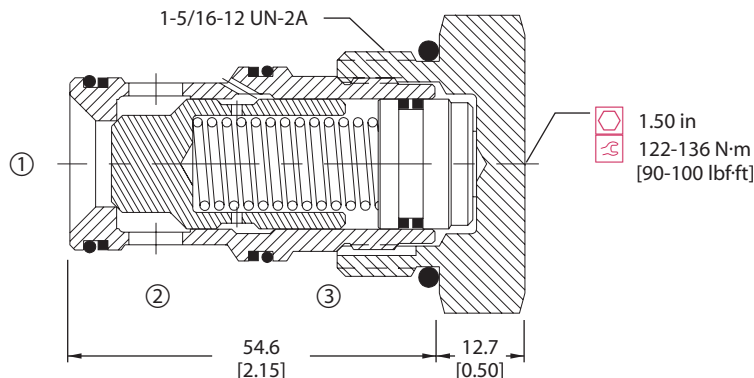

P102 351E

ORDERING INFORMATION

CP462 - 1 - B - 16S - 065 - 0

Seals		Piston seals	
B = Buna-N	Seal kit 120033	0 = No seals	
V = Viton	120034	S = Seals included	
Housing and ports	Housing P/N	Crack Pressure	
00 = No Housing	No Housing	bar [psi]	
6B = Al, 3/4 BSP	CP16-3S-6B/2B	065 = 4.48 [65]	
8B = Al, 1 BSP	CP16-3S-8B/2B		
12S = Al, #12 SAE	CP16-3S-12S/4S		
16S = Al, #16 SAE	CP16-3S-12S/4S		
Other housings available			

P102 082E

Cartridge Valves Technical Information

Pilot operated check valves

Dual Pilot-Operated Checks

CP410-1

OPERATION

This is a dual pilot operated check valve, which uses two CV10-NP check valves.

Schematic

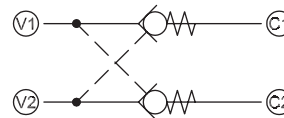

P102 383E

SPECIFICATIONS

Theoretical performance

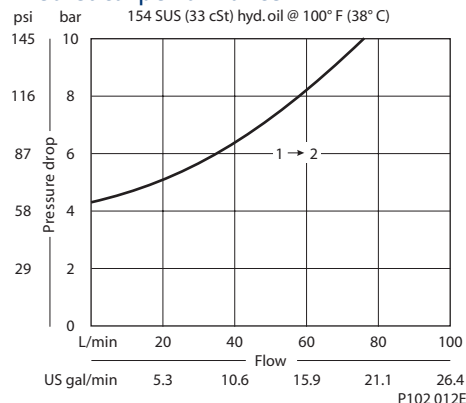

Specifications

Rated pressure	210 bar [3000 psi]
Rated flow at 7 bar [100 psi]	85 l/min [22 US gal/min]
Leakage	6 drops/min @ Rated pressure
Weight	0.67 kg [1.48 lb]
Pilot ratio	4:1
Cavity	none

Note: A piston seal requires a 4.5 bar [65 psi] or greater return spring.

DIMENSIONS

mm [in]

Cross-sectional view

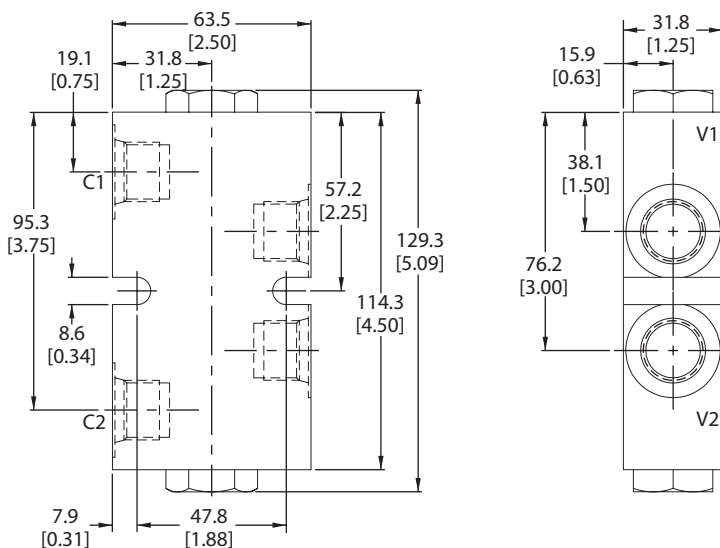

P102 346E

ORDERING INFORMATION

CP410 - 1 - B - 8S - 0 - 065

Seals	Seal kit	W/ piston seals	Crack Pressure	bar	[psi]
B = Buna-N	120072	120176	065	= 4.50	[65]
V = Viton	120161	120177			
Housing and ports	Housing P/N		Piston seals		
6S = Aluminum, #6 SAE	220099		0 = No seals		
8S = Aluminum, #8 SAE	220100		S = Seals included		
3B = Al, 3/8 BSP	221794				
4B = Al, 1/2 BSP	221652				

P102 088E